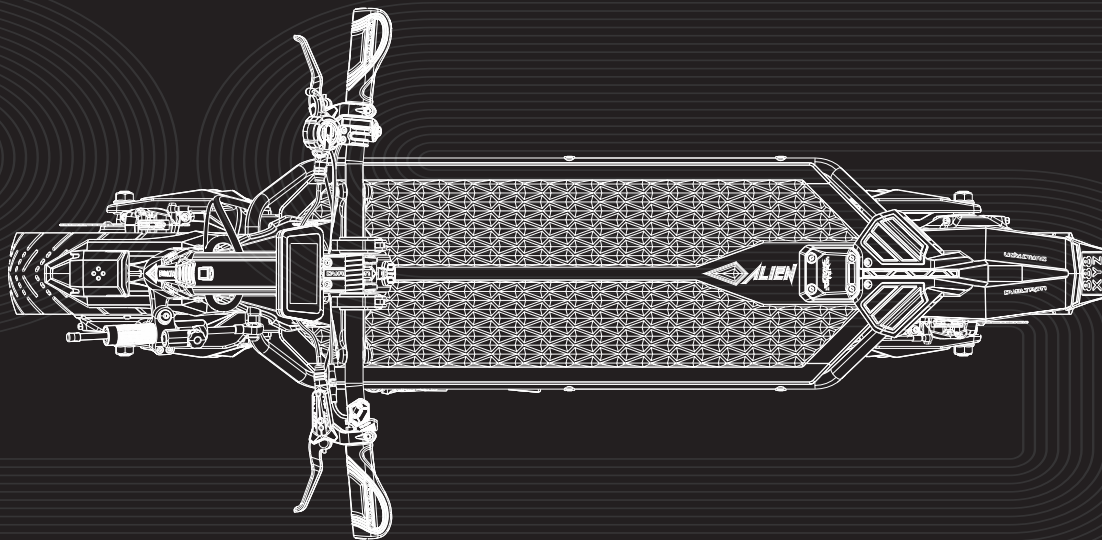


SONIC
DUALTRON
MODEL A

ALIEN



Personal Mobility

PRODUCT MANUAL

RECICLA
RECYCLE



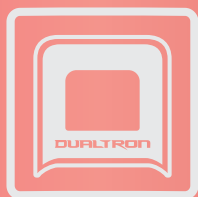


Scan the QR code to download the latest user materials
and obtain the latest updates and safety instructions.

DUALTRON

The dream of electric technology.

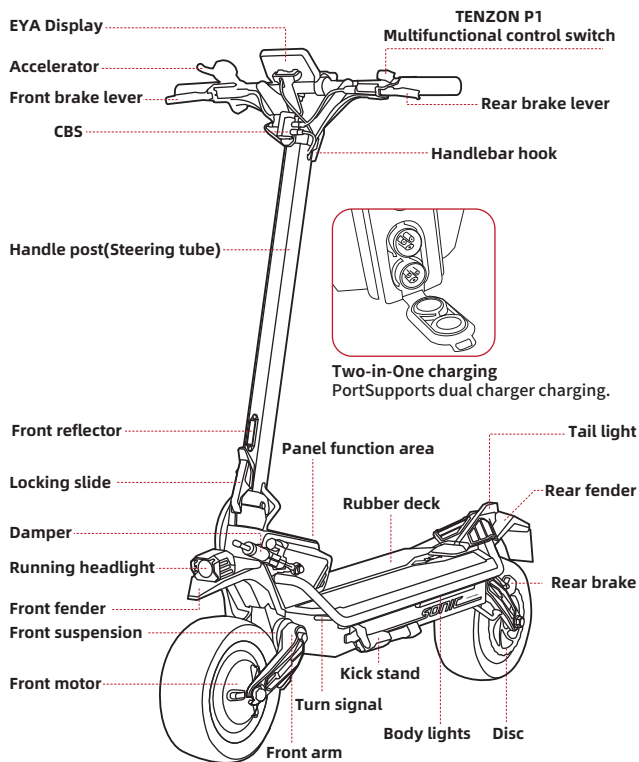
Pictures for reference only, subject to our existing products.



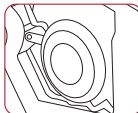
MINIMOTORS



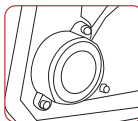
Diagram And Functions



Panel function area



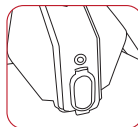
Built-in Mechanical Speaker
May be more stable and reliable underspecific environmental conditions.



Alarm (Fire Alarm)
When the smoke sensor detects smoke or the battery pack temperature is too high, the siren will emit a beeping sound and the warning light will start flashing simultaneously. Due to the non-fully enclosed structure, external high temperatures or smoke may also falsely trigger the alarm.



Charging voltage display during charging



Functions Available When the Power Is On

Single short press of the multi-switch: Turn on the ambient lights
Double short press of the multi-switch: Toggle AVAS on/off
Press and hold the multi-switch for 1 second: Turn off battery monitoring
This function can only be re-enabled through the application.
When battery monitoring is turned off, the smoke sensor and battery pack temperature will no longer be detected, which can help prevent frequent false alarms.

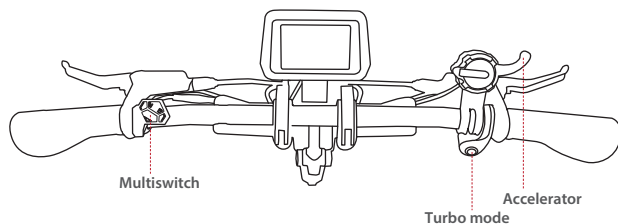
Functions Available When the Power Is Off

Short press of the main switch: Activate anti-theft mode
The switch indicator will blink at 1-second intervals, and the alarm will be triggered.
To deactivate, turn on the main power switch and enter the password to manually disable the alarm.
* In anti-theft mode, the vehicle will sound an alarm and flash the lights if it is moved.
If the vehicle remains stationary for a certain period, it will enter power-saving mode and later return to monitoring mode.

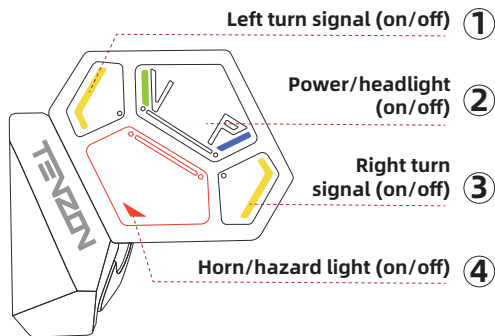


Diagram And Functions

Direction - Function Area



TENZON P1 Multifunctional control switch



① Left turn signal (on/off)

Short press the left button: Turn on/off the left turn signal

② Power/headlight(on/off)

Long press P: To turn on/off the vehicle;

After startup: Short press P once: To switch gears;

Press twice in quick succession: To turn on the headlights and switch the light effect (from low beam to high beam to mixed light in a cycle);

Press three times: To turn off the headlights.

③ Right turn signal (on/off)

Press the right button: Turn on/off the right turn signal

④ Horn/hazard light (on/off)

Short press or long press the horn button: Turn on the horn

Short press the horn button + left turn or right turn button:

Switch on/off the warning light

● Accelerator

Pull the throttle to accelerate.

● Turbo mode

Temporarily boosts the output current to achieve greater power (lasting at least 20 seconds), suitable for overtaking or climbing hills.

After the countdown ends, the Turbo mode automatically exits and returns to standard power output.

Refer to the detailed introduction in the **MAINTENANCE MANUAL**



Specifications

	Item	Parameter
Product	Model	DUALTRON SONIC MODEL A
Battery	Battery Capacity	72V40Ah(SAMSUNG 21700 50S 9C or LG INR21700H51T 9C)
	Range	125km (Under the operating conditions, at a speed of 20 to 30 km/h(with a load of 75 kg))
	Charging Ambient Temperature	-5 to 55°C (Battery temperature exceeds 55°C,BMS start protection program.)
	Battery Management System	CAN Bus Communication
Rider	Max. load	120kg
	Recommended Age	16-60 years old
	Required Height	3'11" -6'6" (120-200 cm)
Display	Type	TFT Color Display(EYA)
	Size Of LCD	3.5 inches
Motor	Motor Type	BLDC Hub Motor
	Nominal Power	2500W x2
	Max. Power	5600W x2
Machine	Net Weight	53.5kg
	Max. Slope	Around 70%[35°]
	Drive System	Two-wheel drive
	Speed	110km/h (measured in a professional experimental site)
	Length × Width × Height	1340×650×1360mm
	Folded: Length × Width × Height	1340×290×580mm
	Wheelbase	Approx.1023mm
	Ground Clearance	Approx.180mm
	Traversable Terrain	Asphalt/flat pavement; obstacles < 5 cm; gaps < 5 cm
	Operating Temperature	-20°C—50°C
	Storage Temperature	-40°C—80°C



Specifications

Brake	Machine Brake	NUTT-linked CBS hydraulic brake, 4-piston, with 160mm disc.
	Electric Brake	EBS+ABS (When the battery temperature is not within the range of -5 to +55°C, the BMS initiates the protection program and the ABS/EBS fails.)
Charger	Input Voltage	AC100-120V/AC200-240V~
	Max. Output Voltage	DC83V±1V/5A±0.5A (Fast charger) &1.4A
Tire	Type	11 inch runflat tire
	Tire Pressure	50PSI
	Material	Rubber
Suspension	Type	Front and rear adjustable cartridge(patent)
	Note	*Change the thickness of the gasket to obtain different shock absorption effects

Disclaimer: This is not a legal opinion or legal advice. The information provided herein (including in the App) is for your convenience and informational purposes only. It is not intended to cover every piece of law and/or regulation that may be applicable to this product. DUALTRON explicitly hereby disclaims any and all warranties and/or representations, express or implied, related to the completeness, accuracy, or up-to-date nature of such information. DUALTRON reserves the right, but not the obligation, to correct, implement, and/or update the information. You shall use the information at your own risk. It is your sole responsibility to learn and understand any and all laws and/or regulations, requirements, prohibitions, restrictions, and/or limitations imposed by law, government authority, court, private party, or other parties that may apply to your use of this product.

Theoretical Range: Tested while riding with a full battery, 75 kg load, 25°C, at an average speed of 25 km/h on pavement.

Typical Range: Tested while riding with a full battery, 75 kg load, 25°C, at an average speed of 50 km/h on pavement. (Some of the factors that affect range include speed, number of starts and stops, ambient temperature, etc.)

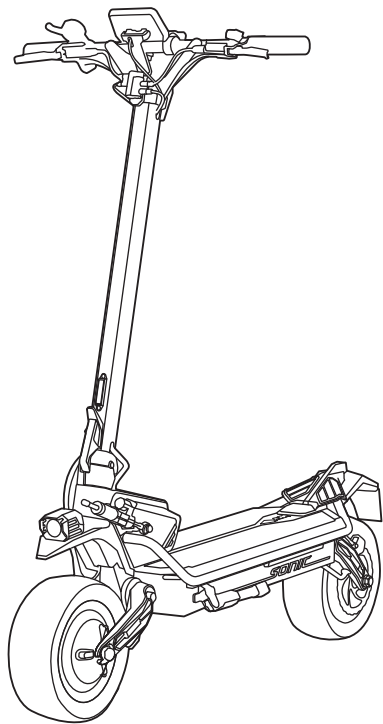
Max. Speed: Tested while riding with a full battery, 75 kg load, 25°C, on a straight, flat road with no wind. (Some environmental factors can affect max speed, such as uneven roads, curved roads, temperature, wind, etc.)

Sound Level: The sound of the scooter exceeds 70 dB during operation.

The specific driving parameters of the vehicle, you can view it yourself after connecting to the APP.



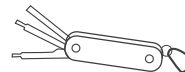
Packing List



Accessories



Main battery charger x2



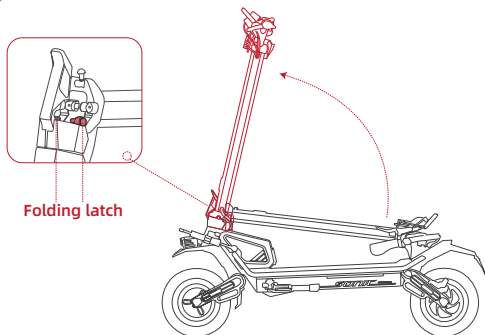
Multitool x 1



Manual



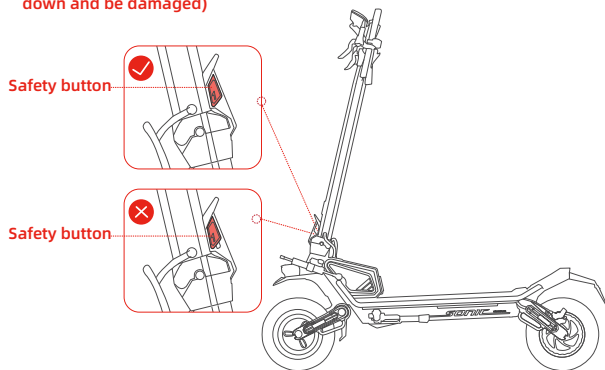
Assembly



Folding latch

① Raise the steering tube and make sure the folding latch gets into the button correctly.

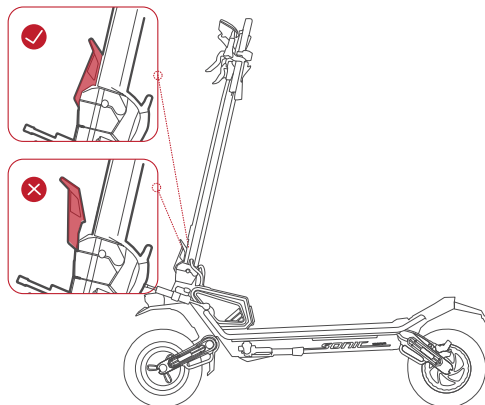
⚠ (Carefully, if the folding latch gets into the button incorrectly, the steering tube will fall down and be damaged)



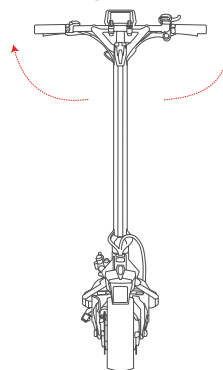
Safety button

Safety button

③ Check the status of the safety button and make sure it is back to position.



② Press down the quick release lever firmly to make sure the folding mechanism is tightened.



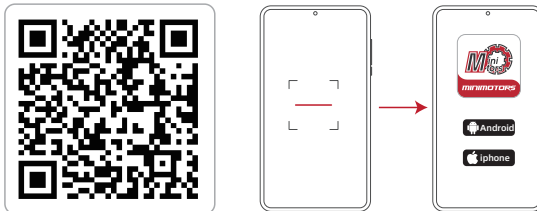
④ Lift the handles, slide the hoops, and fix the handles firmly by quick releases.



Bluetooth Connection

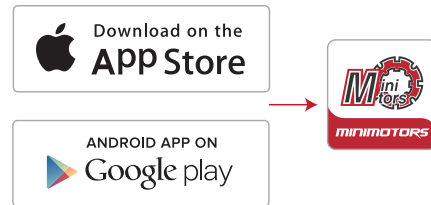
APP Download Guide

Method 1



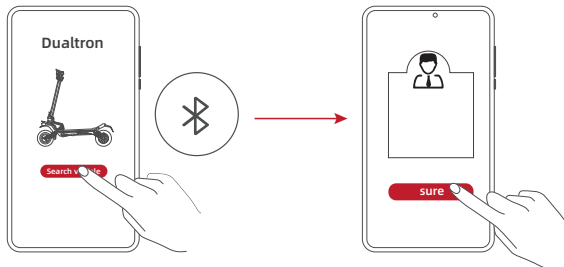
1. Scan the QR code to download the app.
2. Choose the appropriate mobile operating system to install it, then register or log in.

Method 2



1. Search for "DUALTRON" in the app store, download it, then register or log in.

Pair the Bluetooth on the APP

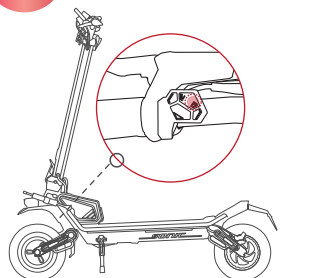


Click "Search vehicle" and pair with your scooter. * The scooter is connected to the Dualtron app when the Bluetooth symbol lights up.

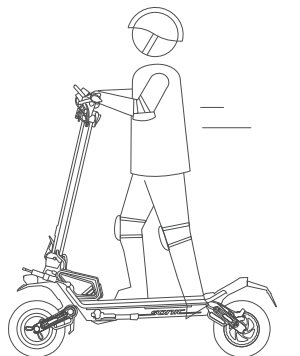
Select "bind as owner".
(No one else can connect, only people authorized by you are allowed to connect. Authorizations are created on the app.)



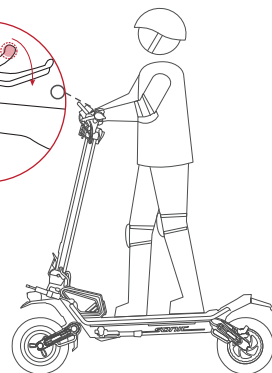
How to Ride



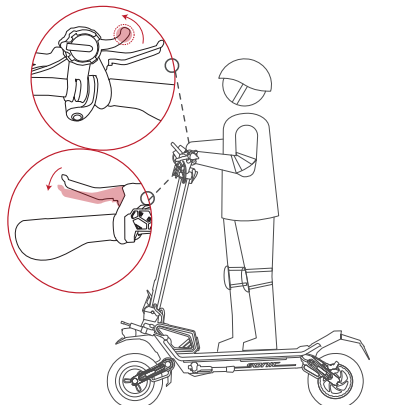
1. Long press P: To turn on/off the entire vehicle



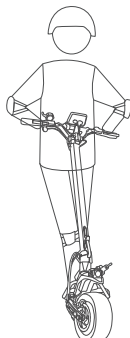
2. Stand on the footboard with one foot and push off with the other foot to start gliding. *Make sure you have disabled SAFE mode. (SAFE mode setting via Dualtron app. Deactivate safe mode by squeezing brake lever.)



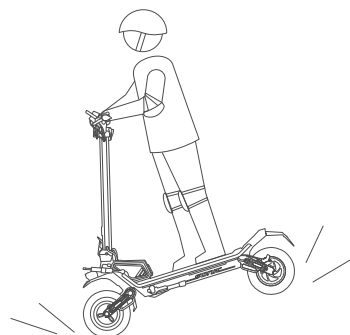
3. Put both feet on the footboard and stand stably. Pull the throttle to speed up.



4. Slow down by releasing the throttle and squeezing brake levers.



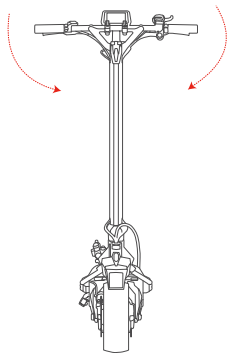
5. To turn, shift your body and turn the handlebar slightly. * Please watch out for road conditions, sufficient turning space is required.



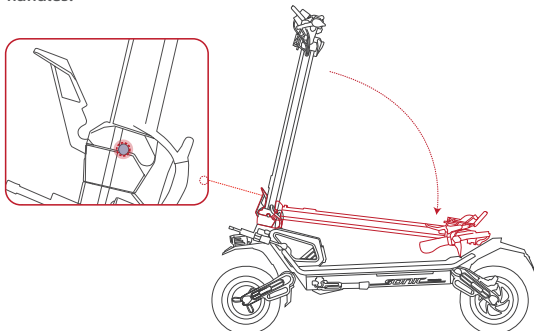
When hard braking, serious danger or injury may occur. Maintain a moderate speed and look out for potential hazards.



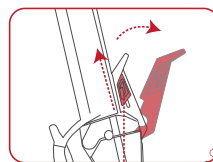
Folding



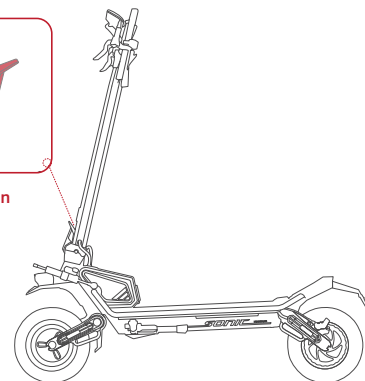
Fold the handlebars, slide the folding handle lock out of position to release handles.



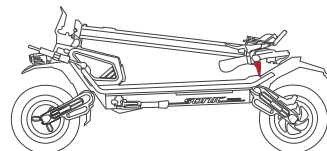
Press both folding latches, then fold the steering tube. **⚠ When pressing the safety latch, you must hold the steering tube with your hand to prevent it from falling and causing damage.**



Safety button



Slide the safety button up and open the quick release lever.



Lock the handlebar hook to the footrest.
⚠ Ensure the handlebar is locked before lifting the scooter.

MEMO